



Improving runoff estimates using remote sensing vegetation data in bushfire impacted catchments

Yongqiang Zhang and Yanchun Zhou

CSIRO Land and Water

26 June 2012

Outline

- Introduction
- Catchment and data
- Modelling framework
 - Xinanjiang (XAJ) model
 - XAJ-ET model
- Results and discussion
- Summary

Introduction

- A challenge for accurate estimates of streamflow in bushfire impacted catchments for better water resources management
- Rainfall-runoff models widely used for surface runoff prediction due to their simple structure and few parameters. Surface vegetation information seldom considered in rainfall-runoff modelling
- It is expected that streamflow is increased in 3-5 post-bushfire years
- Our main objectives:
 - (1) to incorporate remote sensing LAI data into a modified rainfall-runoff model;
 - (2) to investigate its skills for runoff simulations (until 5 years after bushfires) in bushfire-impacted forest catchments;
 - (3) to identify the contribution of LAI time series data for streamflow estimates.

Catchment and Data: catchment and burnt area

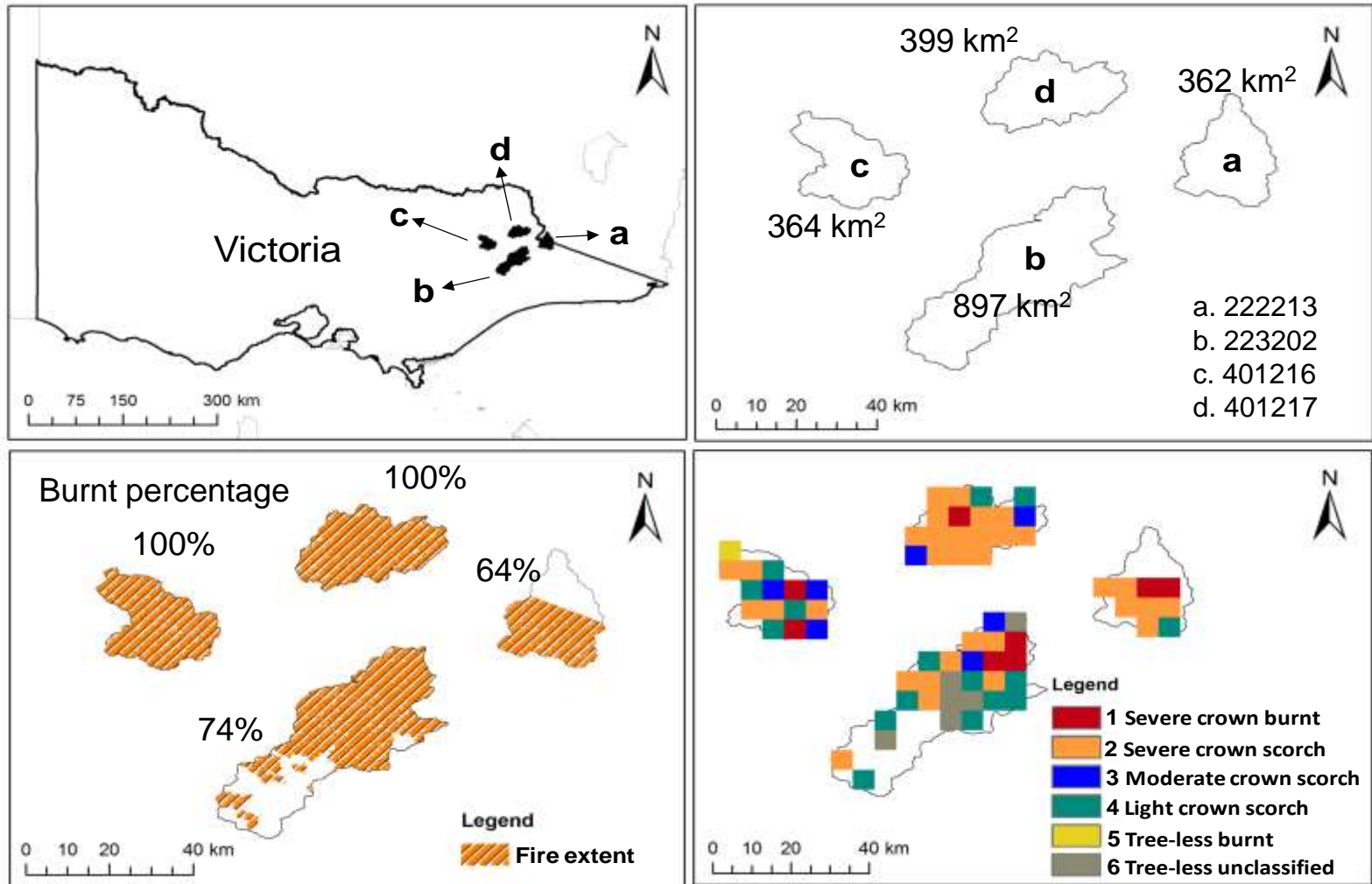

Location map, 2003 fire extent and fire severity for the four study catchments

Catchment and Data: data input

- Daily streamflow data
- Daily climate data (SILO)
P, Tmax, Tmin, VP and S

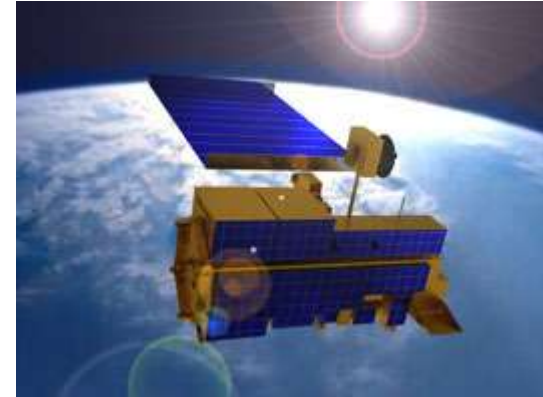

- MODIS LAI/albedo time series data

The 8-day composite LAI products (MOD15A2, collection 4) and albedo product (MCD43B3) for the period 2000-2008.

- Land cover data

Obtained from the yearly MODIS Land Cover classification product (MOD12Q1).

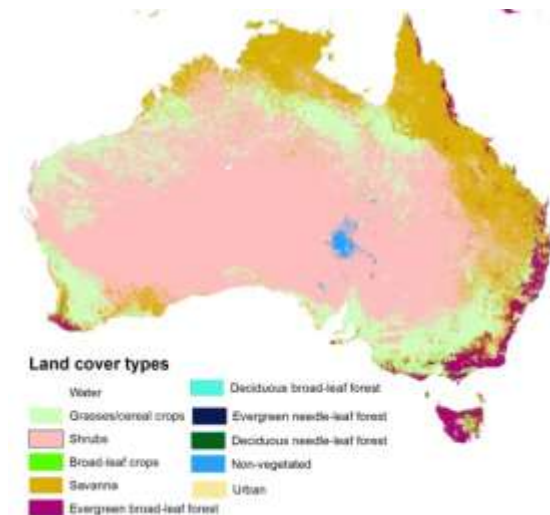

Catchment and Data: LAI time series

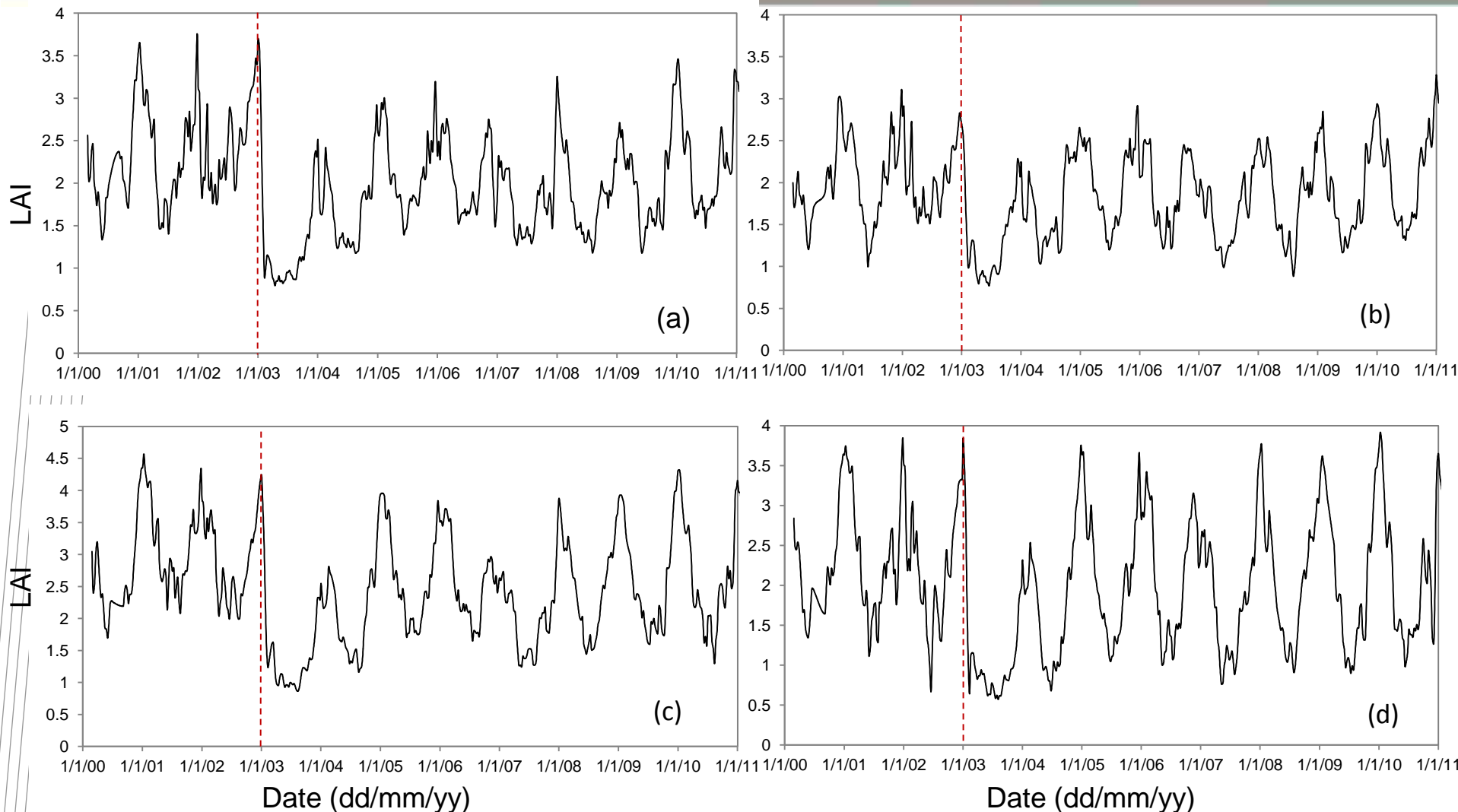

LAI time series for (a) 222213; (b) 223202; (c) 401216; (d) 401217

Catchment and Data: Changes in mean annual LAI

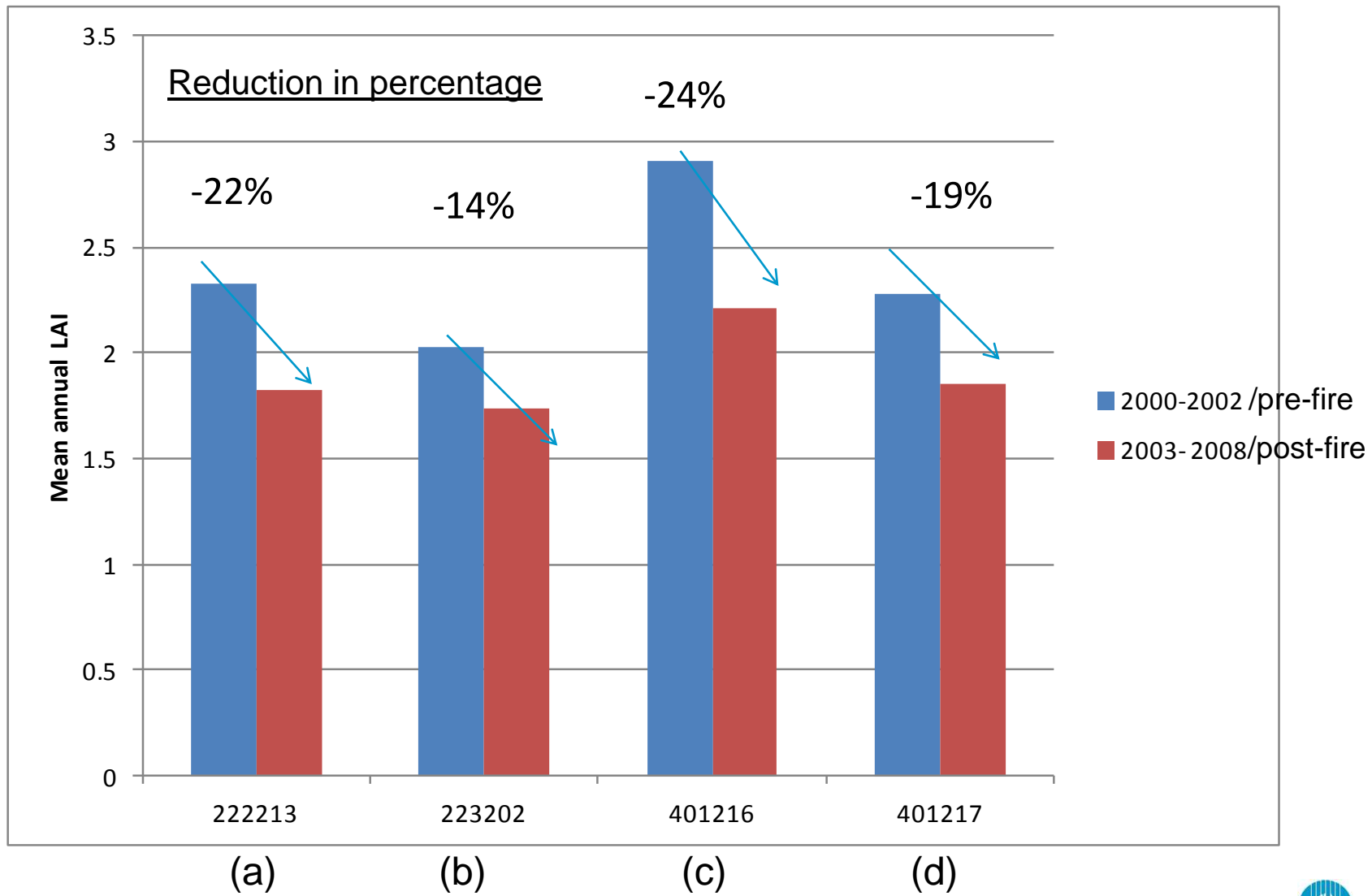

Catchment and Data: Changes in Q, P and PET

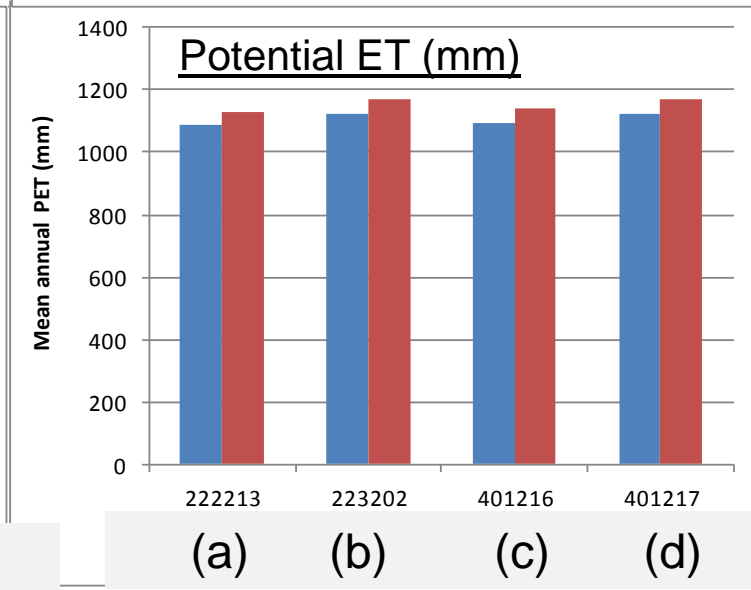
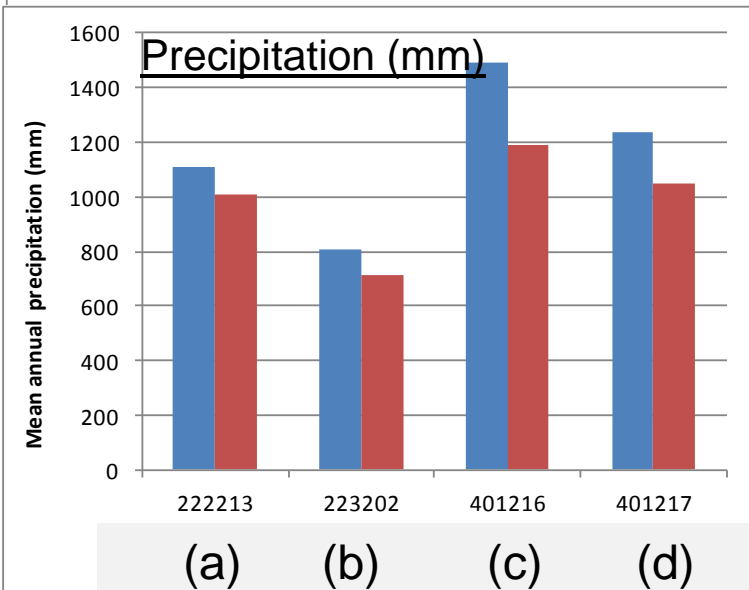
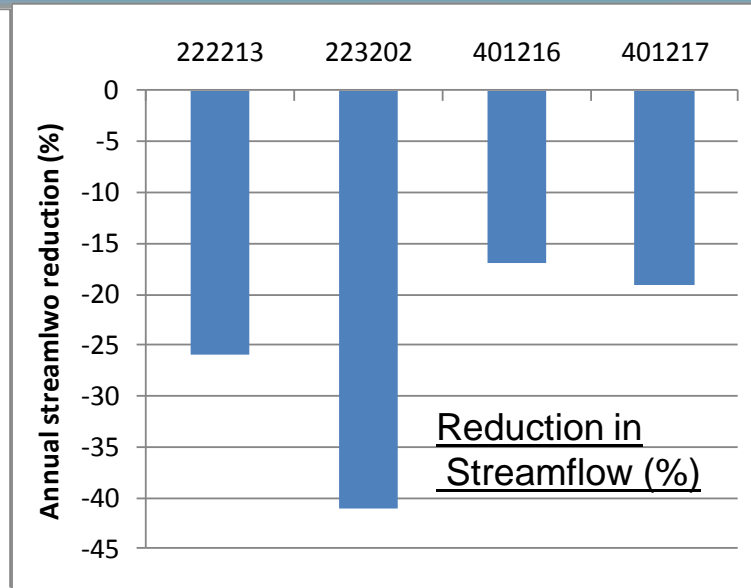
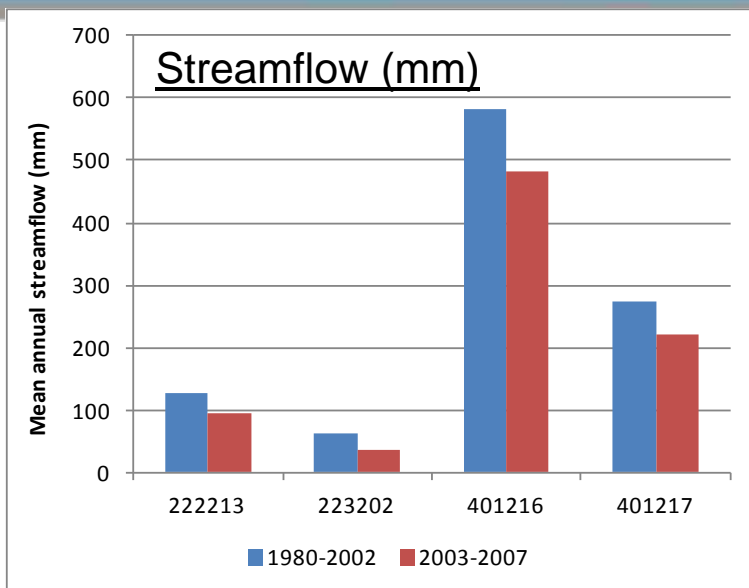

(a) (b) (c) (d)

(a) (b) (c) (d)

Catchment and Data: causes for changes in Q

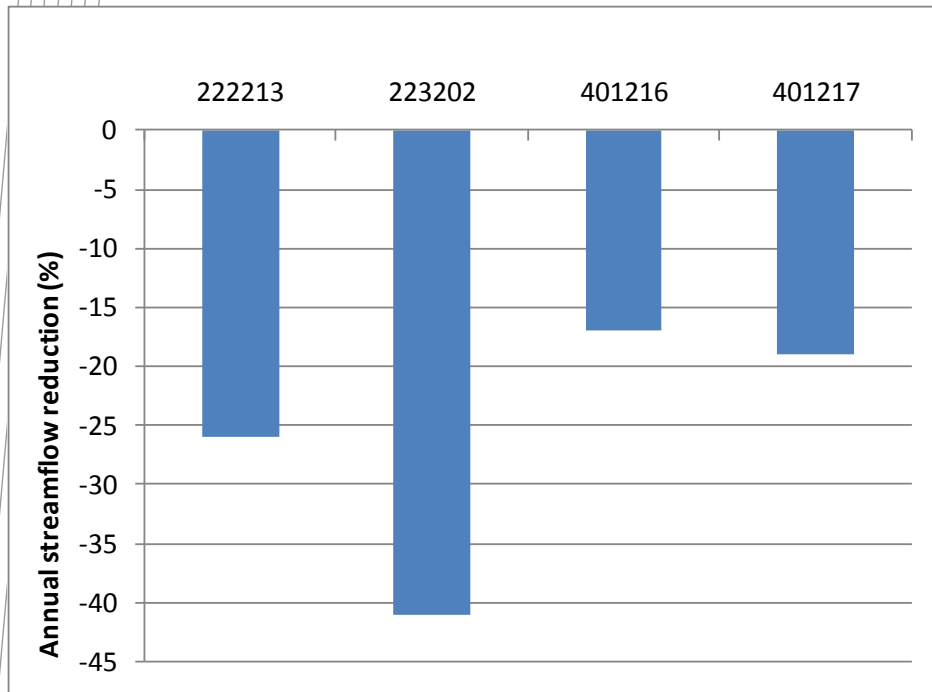

Statistical analysis on reduction in mean annual runoff between pre- and post-bushfire periods

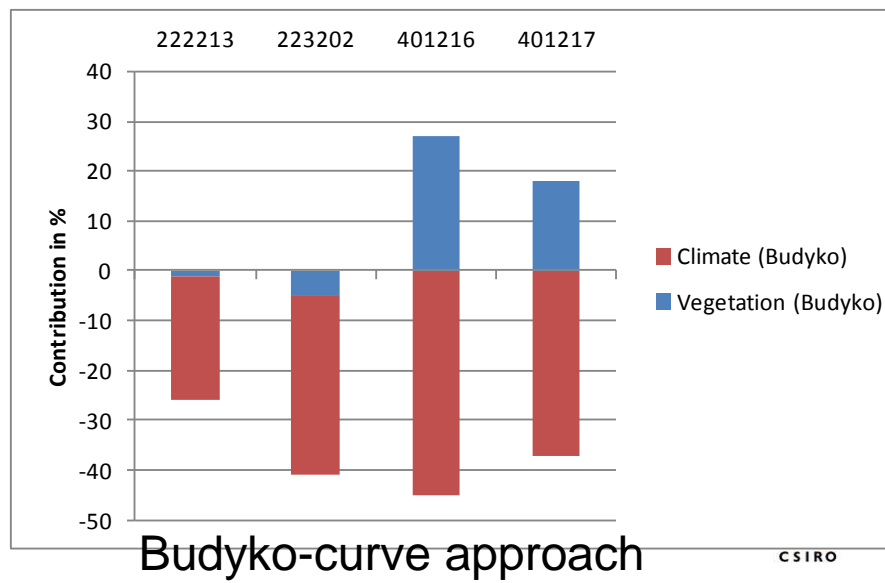
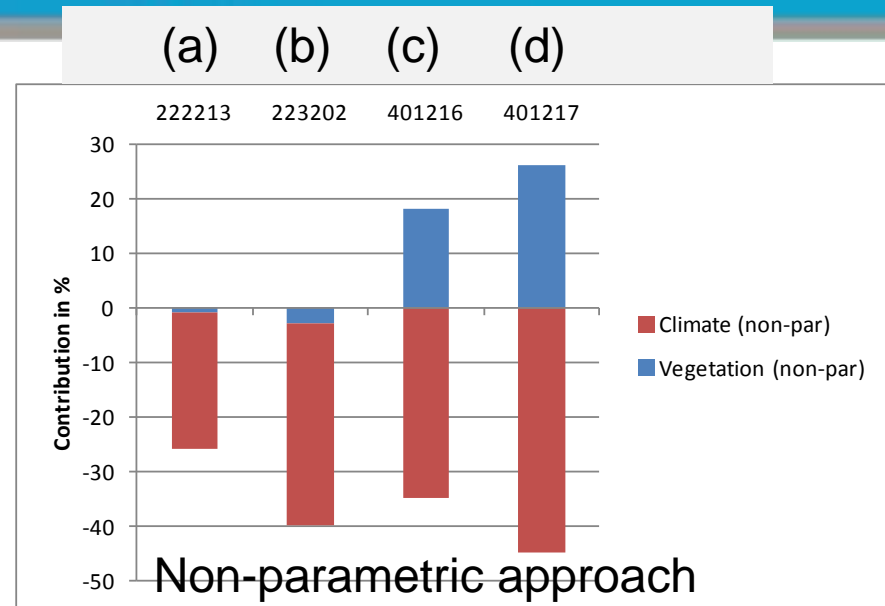

Modelling framework: XAJ and XAJ-ET models

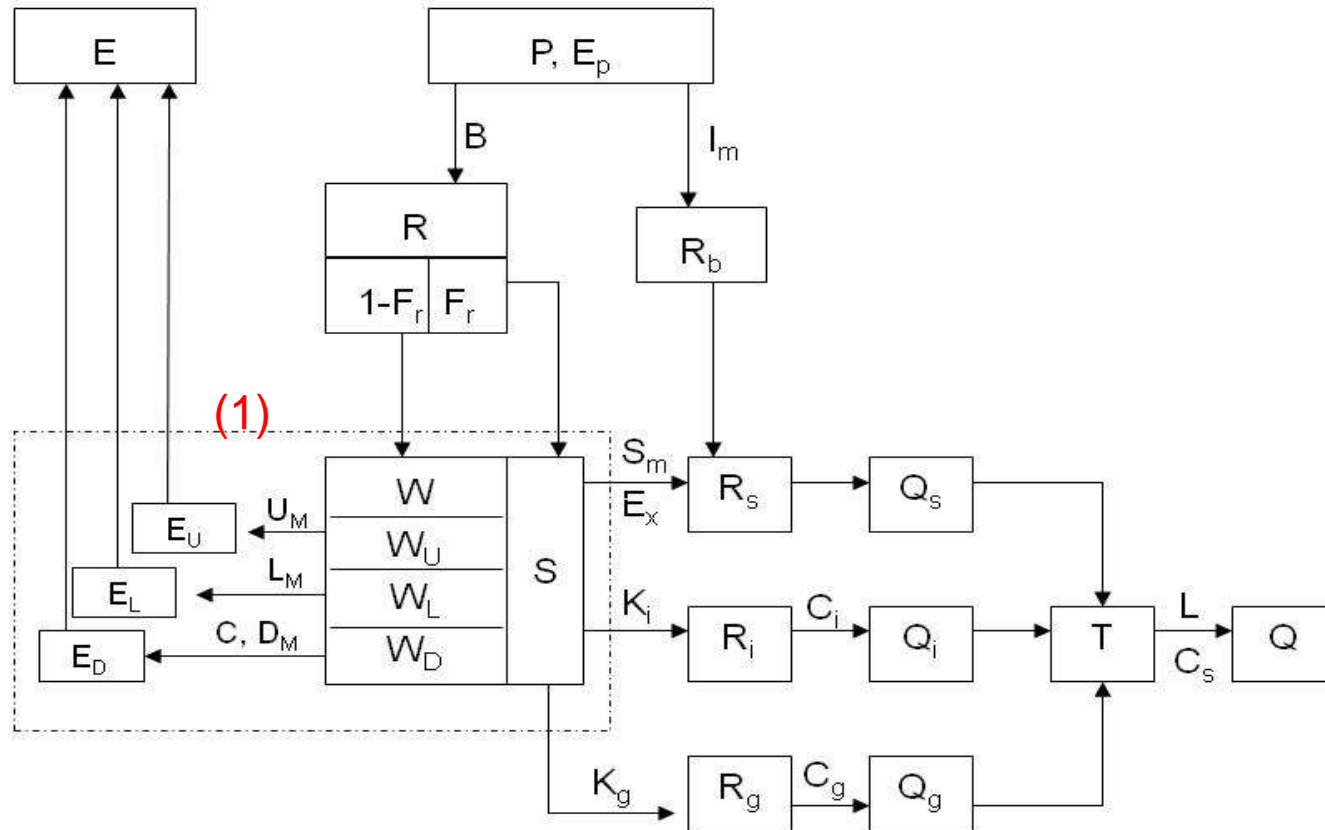

Model structure for Xinanjiang (XAJ) model

Modelling framework: ET submodel

Penman-Monteith-Leuning ET model:

$$E = \frac{1}{\lambda} \frac{\varepsilon A + (\rho_a C_p / \gamma) D_a G_a}{\varepsilon + 1 + G_a / G_s}$$

$$G_s = G_c \left[\frac{1 + \frac{\tau G_a}{(1 + \varepsilon) G_c} \left[f - \frac{(\varepsilon + 1)(1 - f) G_c}{G_a} \right] + \frac{G_a}{\varepsilon G_i}}{1 - \tau \left[f - \frac{(\varepsilon + 1)(1 - f) G_c}{G_a} \right] + \frac{G_a}{\varepsilon G_i}} \right]$$

$$G_c = \frac{g_{sx}}{k_Q} \ln \left[\frac{Q_h + Q_{50}}{Q_h \exp(-k_Q \text{LAI}) + Q_{50}} \right] \left[\frac{1}{1 + \frac{D}{D_{50}}} \right]$$

XAJ-ET model: G_c modified to take soil moisture into account

$$G_c = \frac{g_{sx}}{k_Q} \ln \left[\frac{Q_h + Q_{50}}{Q_h \exp(-k_Q \text{LAI}) + Q_{50}} \right] \left[\frac{1}{1 + \frac{D}{D_{50}}} \right] \alpha \frac{SMS}{SMSC}$$

Modelling framework: three experiments for XAJ-ET

- In the **pre-bushfire** (calibration) period, the XAJ model and XAJ-ET model (with LAI time series inputs) calibrated against observed streamflow at each catchment
- In the **post-bushfire** (simulation) period , the XAJ model taken as a reference for evaluating the XAJ-ET model for which three modelling experiments are conducted:

- ✓ **XAJ-ET- I :**

- Mean annual LAI of pre-bushfire period

- ✓ **XAJ-ET- II :**

- Mean annual LAI of post-bushfire period

- ✓ **XAJ-ET- III :**

- Actual LAI time series of post-bushfire period

Results: model performance (Nash-Sutcliffe Efficiency of daily runoff)

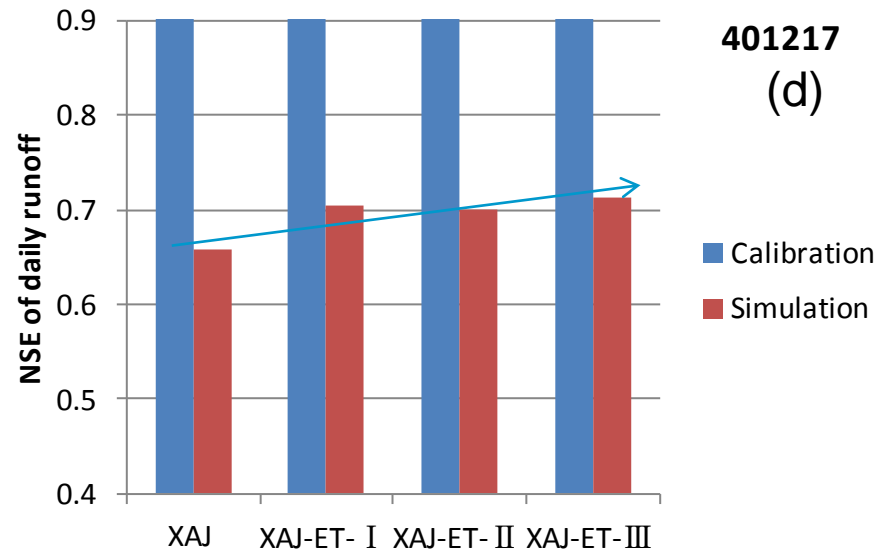
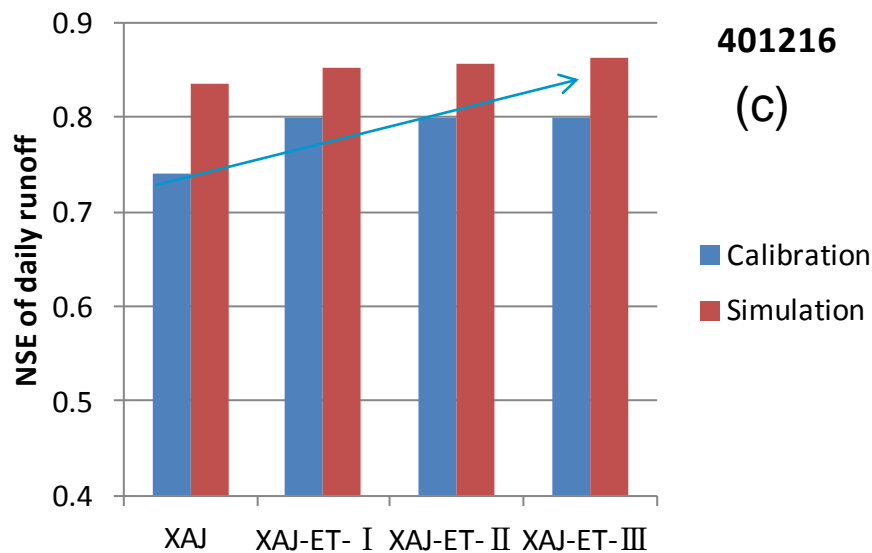
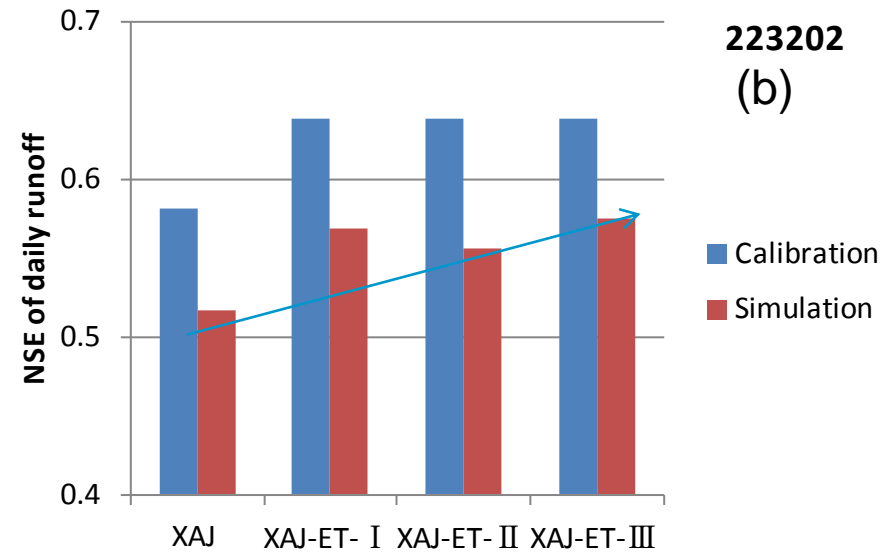
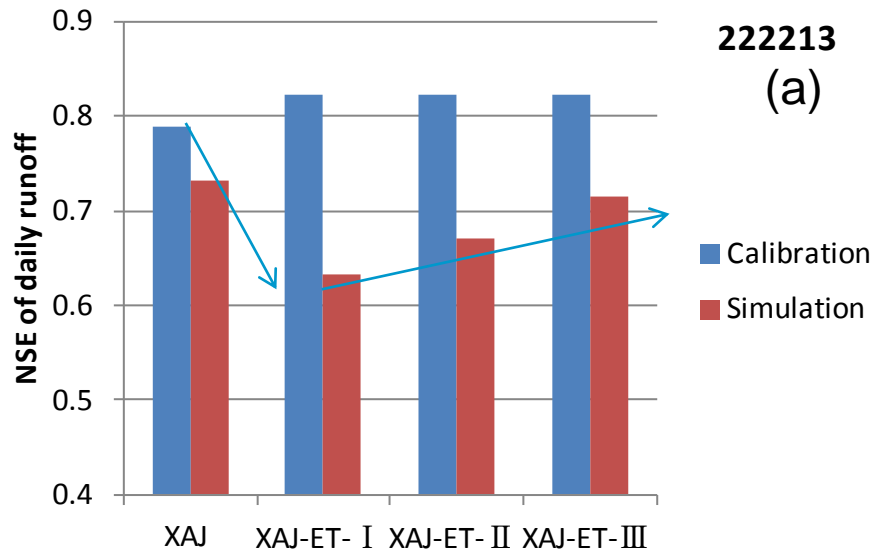

Results: model performance (water balance error in %)

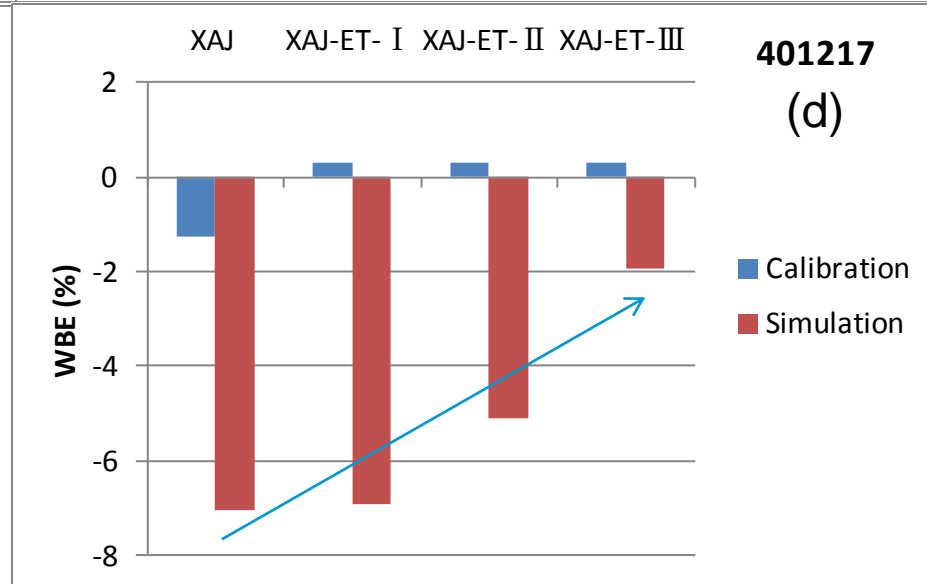
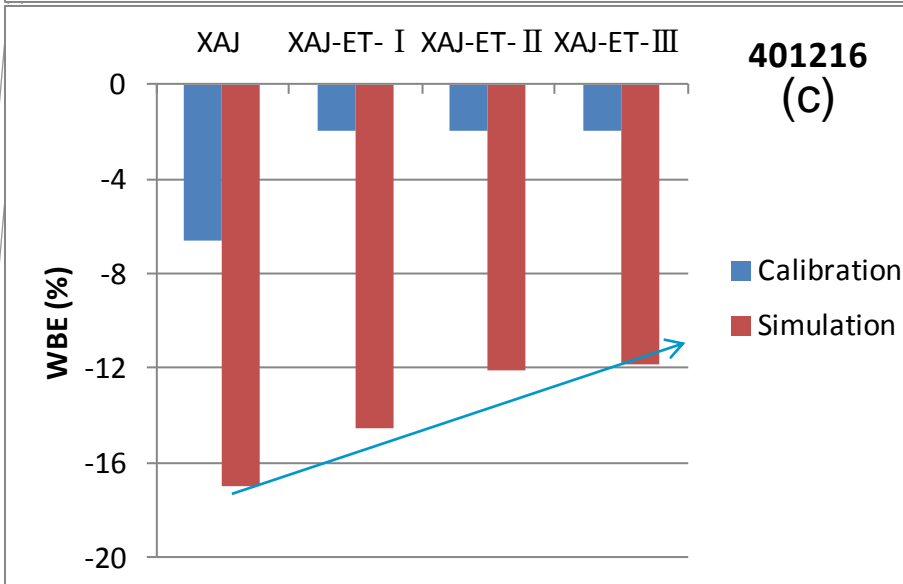
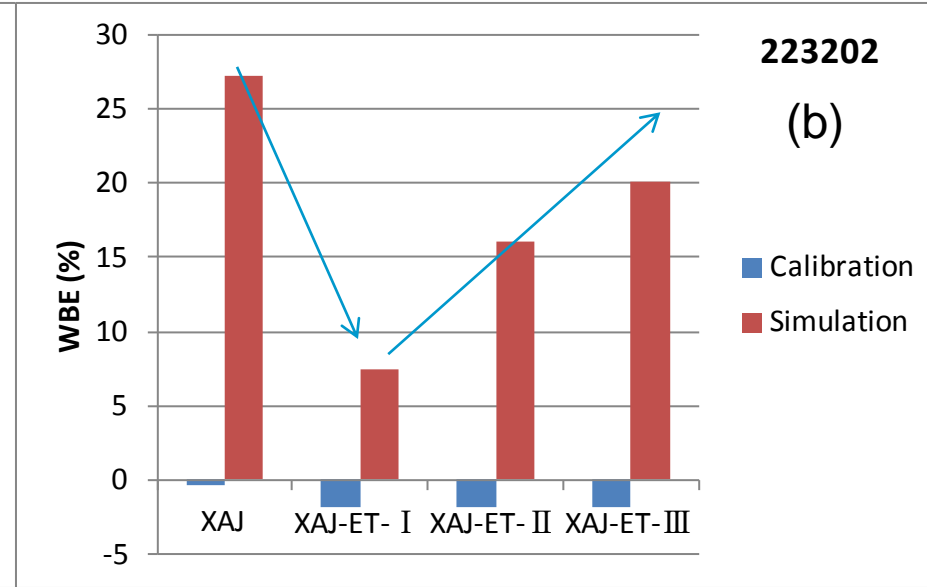
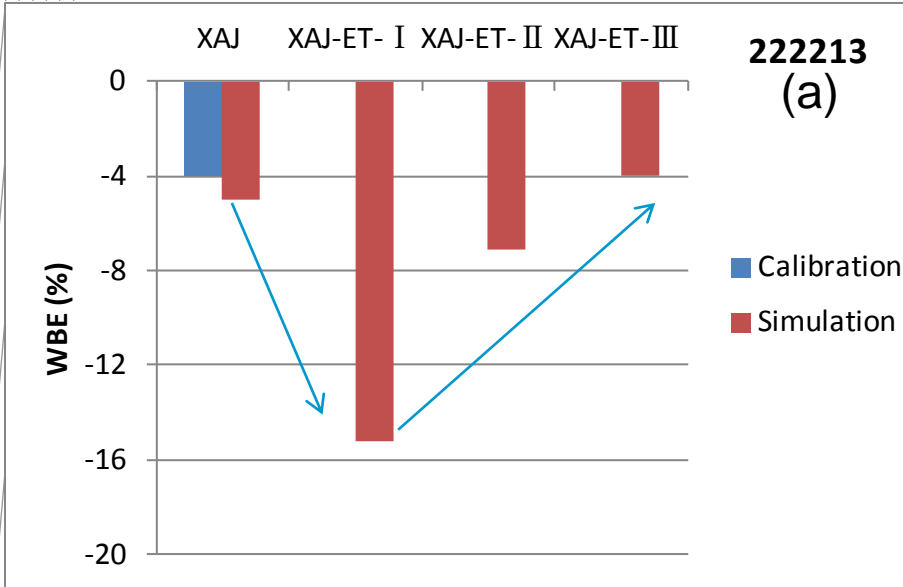

Result discussion: causes for changes in Q

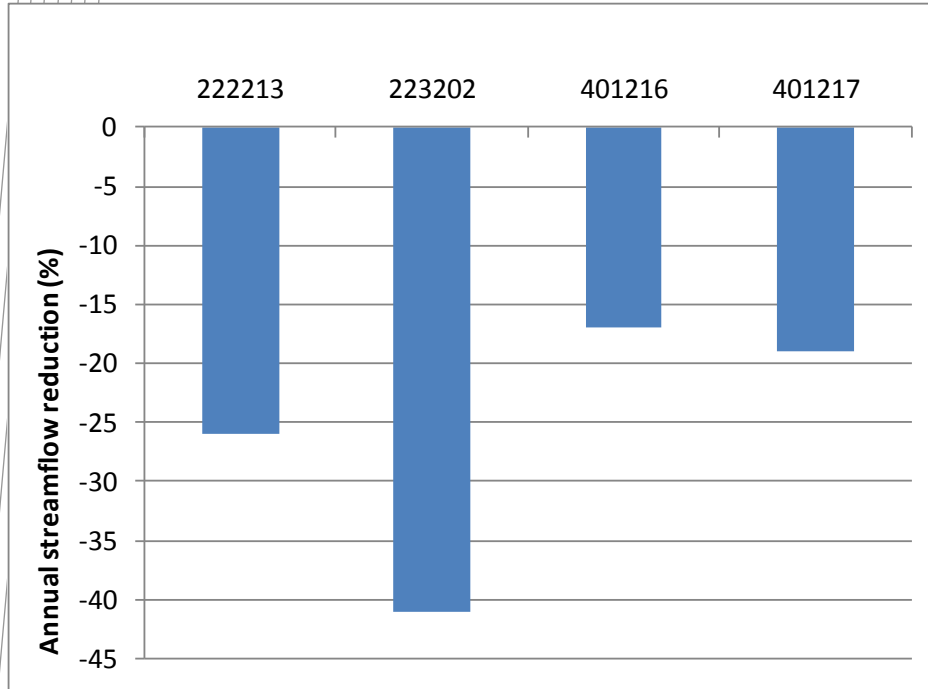

Statistical analysis on reduction in mean annual runoff between pre- and post-bushfire periods

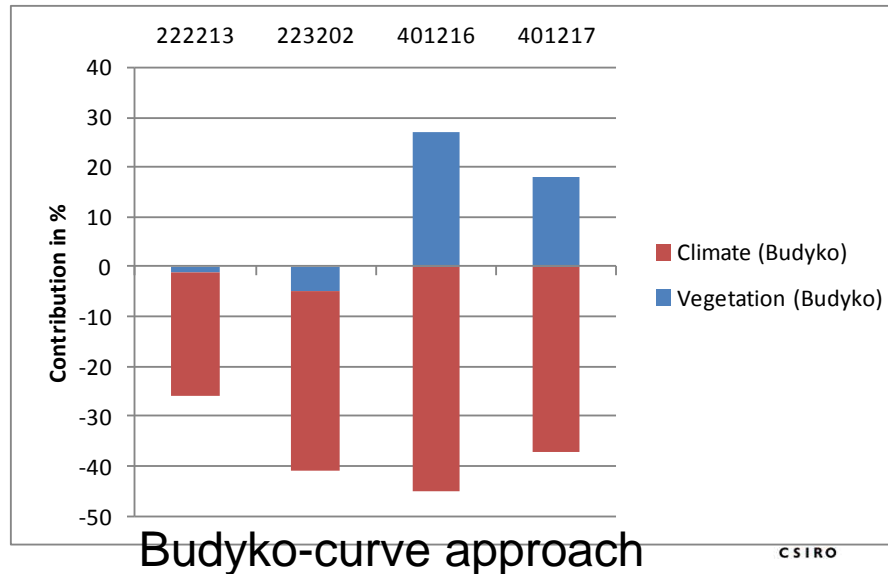
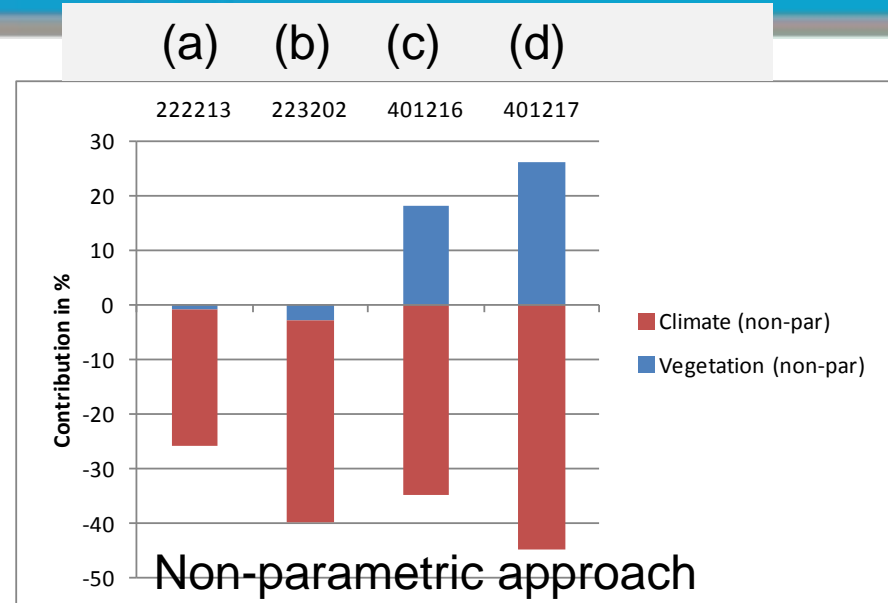

Result discussion: Actual ET dominated by equilibrium ET

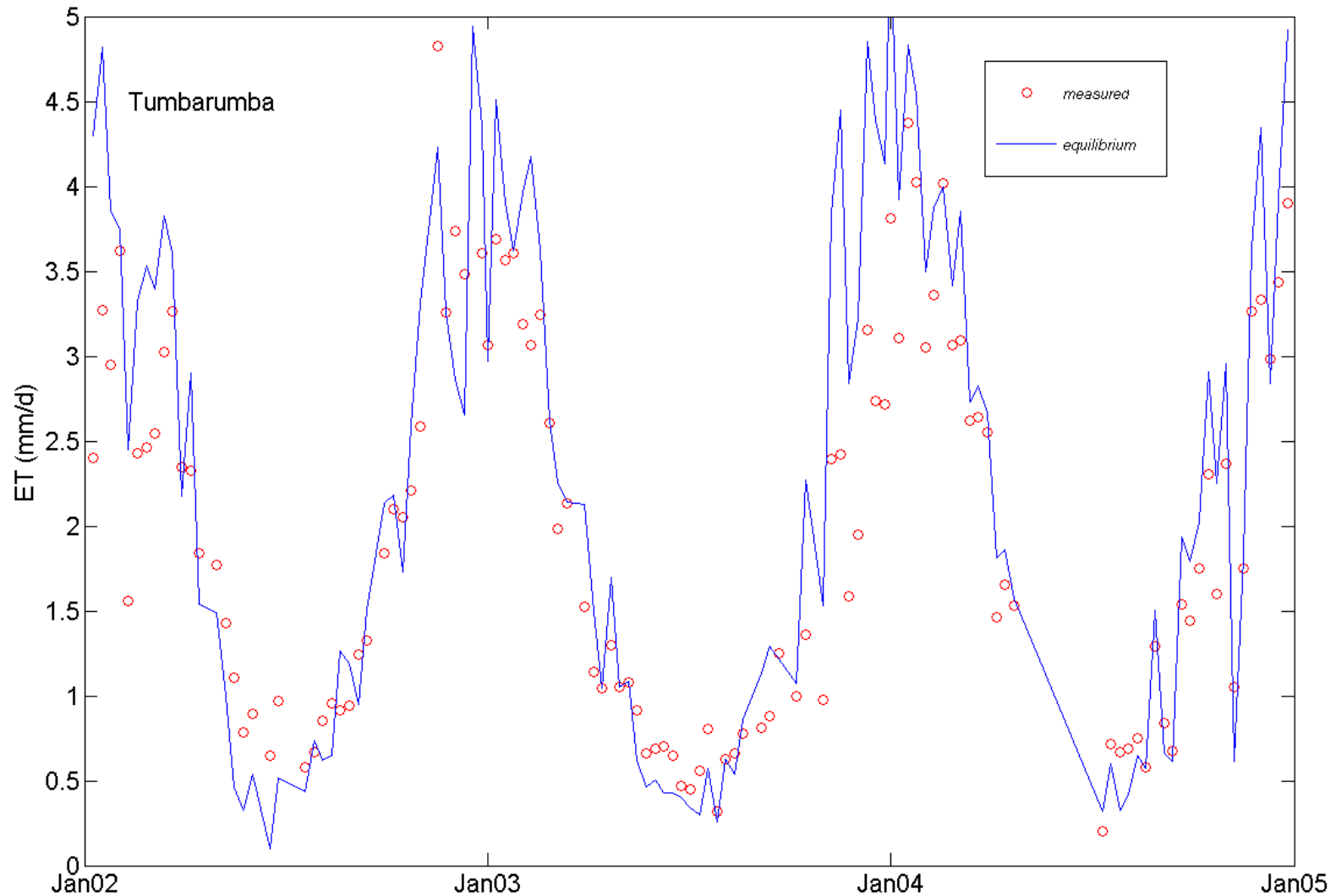

ET time series obtained from Leuning et al. (2008)

Summary

- The impact of 2003 bushfire on streamflow for the four VIC forest catchments not noticeably as imagined
- Incorporation of remote sensing LAI data into the modified rainfall-runoff model can improve model performance in bushfire impacted catchments, but not guaranteed
- It is more likely to improve runoff estimates using vegetation data in the catchments where bushfire plays an important role in controlling runoff.
- The improvement attributes to the improvement of model structure and input of LAI time series as well
- More studies need to be done to identify the usability of vegetation dynamic data in rainfall runoff modelling in different climate regimes, especially for the catchments where actual ET is not dominated by equilibrium ET

Thank you!